



# Huppenkothen added-value equipment:

**There is additional equipment that everyone wants.**

You therefore get all as standard from Huppenkothen. This makes your excavator more effective, faster and more comfortable.

**Put simply - added value.**



Exclusive additional equipment



Powerful



Spacious and comfortable operator cabin



Adjustable flow rates

## || CAB WITH COMFORT EQUIPMENT

Comfort cabin ROPS (ISO12117-2) / OPG (ISO10262 Level I) / TOPS (ISO12117)

5,7" multifunction color display

Heating and radio

Air conditioning with 4 outlet nozzles (optional)

Mechanically cushioned comfort seat - with head rest

HFM (HUPPIFleetManagement) - telematics system with 2 year term of use, extended for additional charge

ECO mode - to increase economic efficiency

Automatic idle speed control - optimised fuel consumption

Sun shield

## || TECHNICAL AND SAFETY EQUIPMENT

Double air filter - additional protection for the engine

Spring-loaded accumulator on parking brake

Spring-loaded accumulator on slew brake

Electric refuelling pump

Pressure accumulator for pressure relief of hydraulic circuits and emergency boom lowering

Storage compartment with on-board toolkit

Acoustic overload warning device (EN474-5)

LED worklights

2 x cab at front, 2 x cab at rear, 1 x engine hood at front, 1 x boom

Socket on cab roof for rotary beacon

## || HYDRAULICS

4 hydraulic auxiliary circuits, 3 of which have proportional control

Flow rates adjustable on the display

1<sup>st</sup> circuit: 3 memories, 2<sup>nd</sup>/4<sup>th</sup> circuit: 1 memory

1<sup>st</sup> hydraulic auxiliary circuit, with proportional control - max. 60 l/min

2<sup>nd</sup> hydraulic auxiliary circuit, with proportional control - max. 22 l/min

3<sup>rd</sup> hydraulic auxiliary circuit, for hydraulic quick change plate HUPPPlate H

4<sup>th</sup> hydraulic auxiliary circuit, with proportional control - max. 22 l/min

Detent Mode - breaker line continuous operation

Hydraulic tank ventilation

Pilot-opened load-holding valve on boom cylinder and arm cylinder

End position damping at boom and swing cylinder

Optional additional equipment and services

### HUPPLub

Huppenkothen central lubrication system to ensure everything runs even more smoothly.

### HUPPView

Bucket position control system for precise work.

### HUPPLevel

Automated levelling and planing.

### HUPPIWarranty

Extended premium warranty package with all-round protection.

### HUPPIFleetManagement

An eye on every machine at all times with fleet management. First 2 years included in purchase price.



The Takeuchi **TB235-2** is a versatile, well-balanced machine with exceptional excavating performance. The mini excavator comes with 4 hydraulic circuits that offer many possible applications without loss of performance. Its spacious operator cabin offers lots of comfort.



- › 1<sup>st</sup> hydraulic circuit, with proportional control with 60 l/min
- › 4 hydraulic circuits, 3 of which have proportional control; adjustable flow rates
- › 6 LED worklights for optimum illumination of working area
- › Available in 3 versions: with canopy or with comfort cabin with or without air conditioning



**For three hours, two days  
or a whole year** - if you need  
it for your construction site,  
you can **buy and rent** your  
TB235-2 from us.



**TAKEUCHI**

**TB235-2**

Mini excavator with cabin

MAIN DIMENSIONS	
Service weight* (kg)	3.640
Total width (mm)	1.580
Overall height (mm)	2.495
Transport length - dozer blade at the rear (mm)	5.230
Digging depth (mm)	3.245
Reach (mm)	5.255
Arm length (mm)	1.450
Tail swing radius (mm)	1.330
Tracks	Rubber
Track width (mm)	300
Ground contact (mm)	1.645
Ground pressure (kg/cm <sup>2</sup> )	0,31
Ground clearance (mm)	295
Dozer blade dimensions (mm)	1.580 x 395

\* Machine weight + PT + HUPPPlate + medium size bucket + half a tank of diesel

ENGINE	
Type	Yanmar 3TNV88F 3-cylinder diesel engine Stage V emission level
Rated output ISO14396 (kW)	18,2 kW @ 2.400 r.p.m.
Displacement (cm <sup>3</sup> )	1.642
Fuel tank (l)	46

WORK PERFORMANCE	
Travel speed (km/h)	2,8 (1 <sup>st</sup> gear) / 4,2 (2 <sup>nd</sup> gear)
Slew speed (rpm)	9,3
Gradeability (degrees/%)	30 / 58
Boom swing angle l/r (°)	70 / 55
Digging force bucket (kN)	27,1
Digging force arm (kN)	17,3
Digging force boom (kN)	17,1

HYDRAULIC SYSTEM	
Hydraulic pumps	2 x variable axial piston pump + 2 x gear pump
Pump pressure (bar)	245 x 245 x 200 x 34
Flow rate (l/min)	38,9 x 38,9 x 21,6 x 10,8
Hydraulic tank (l)	35 (Tank) / 68 (total)
Slew motor type	Axial piston motor, rigid
Travel motor type	Axial piston motor, variable

AUXILIARY CONTROL CIRCUITS	
1 <sup>st</sup> control circuit hydraulic breaker (l / min) adjustable flow rate 3 memories for the flow rates	60
2 <sup>nd</sup> /4 <sup>th</sup> control circuit Powertilt / grab (l / min) adjustable flow rate 1 memory for the flow rate	22

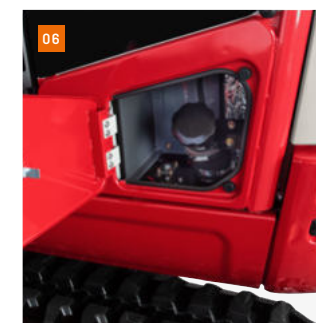
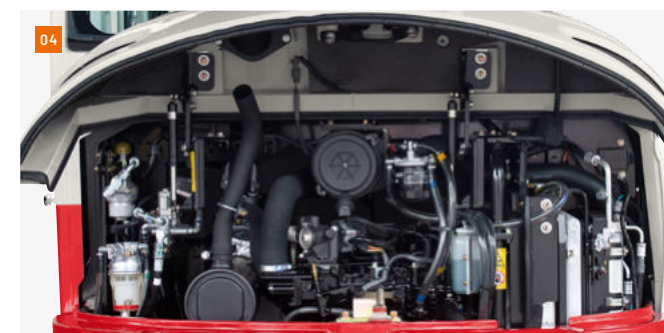
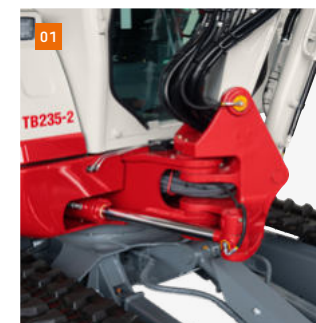

- 01 Robust boom swing assy with specially protected hose guide and hydraulic boom swing; lifting and swing cylinder with end position damping; illustration with central lubrication system HUPPLub.
- 02 Sound-damped, low-vibration comfort cab with mechanically cushioned comfort seat with headrest.
- 03 Optimally arranged controls with large, clear and user-friendly display.
- 04 Generous maintenance hatches for optimum accessibility 05 to hydraulic and fuel maintenance components, battery and radiator.
- 06 Lockable refuelling flap

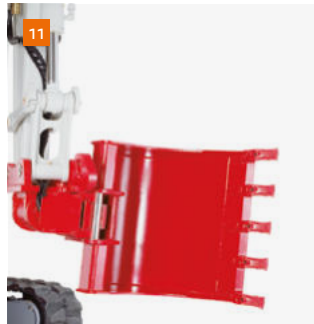
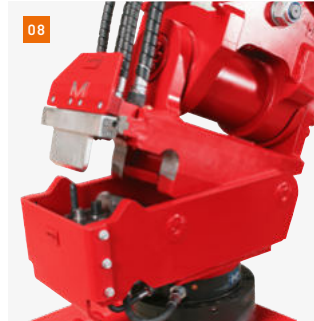
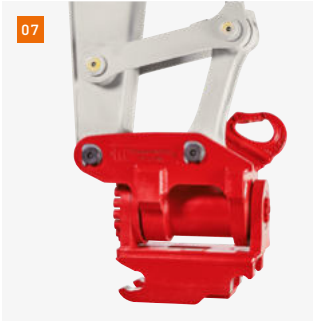

- 07 HUPPTilt tilt device with hydraulic quick change plate HUPPPlate H
- 08 HUPPQuick quick coupling system: Hydraulic connections are connected automatically during the quick coupling process
- 09 HUPPBREAK hydraulic breaker 102
- 10 HUPPGrip universal grabber UG04 II with HUPPTilt
- 11 HUPPTilt with HUPPPlate H, digging bucket can be mounted as high bucket
- 12 Earth drill - 4500 MAX
- 13 Add-on compactor - Ammann APA20/30
- 14 Wood grapple - Lasco LA1200HZ



More accessories at  
[huppenkothen.com/  
 excavator-accessories](http://huppenkothen.com/excavator-accessories)

### Lifting load (kg) TB235-2 cabin

Forward (upper dozer blade)

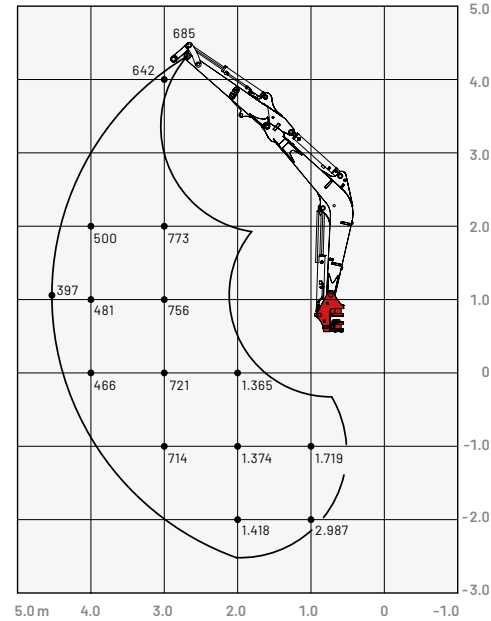

The loads in the diagram are within 87% of the hydraulic lifting load and within 75% of the tipping load.

### Dimensions (mm) TB235-2 cabin

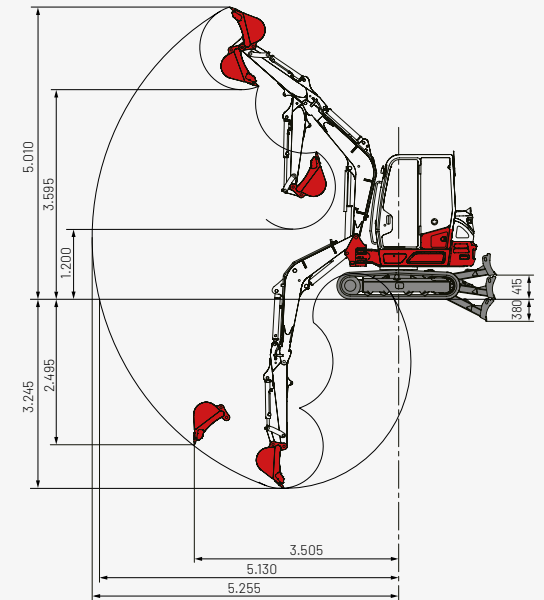
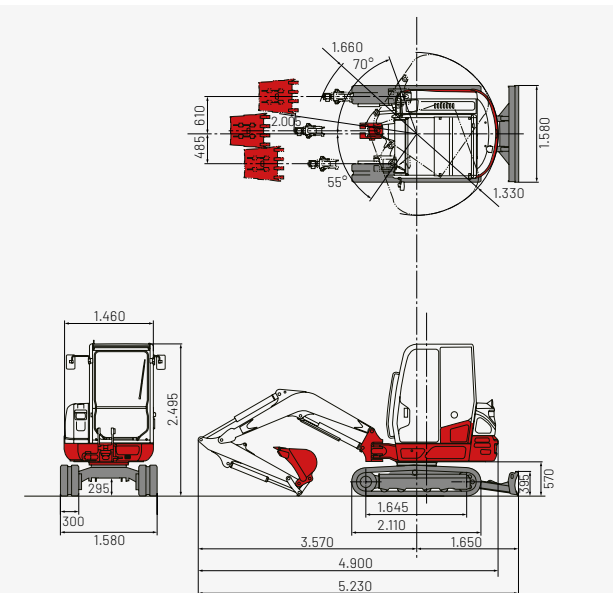

## Huppenkothen – your construction site, your partner, your success!

If you're looking to buy or rent a construction machine, if quality is important to you and you have no time to lose, then you've come to the right place with Huppenkothen. We provide all you need for your construction site. If you have any questions:

**We are always available.**

**41**  
Locations

**350**  
Employees

**4.500+**  
Machines

**100 %**  
Service

### AUSTRIA (AT)

/

#### Huppenkothen GmbH

Bundesstraße 117 / 6923 Lauterach  
T +43 50 663 400 / F +43 5574 778 24  
info@huppenkothen.com

### SWITZERLAND (CH)

/

#### Huppenkothen Baumaschinen AG

Hinterwiden / 9245 Oberbüren  
T +41 71 944 18 11 / F +41 71 944 18 69  
oberbueren@huppenkothen.com

### SOUTH-TIROL (IT)

/

#### Huppenkothen GmbH / SRL

Peter-Anich-Straße 1 / 39011 Lana (BZ)  
T +39 0473 491 170 / F +39 0473 491 171  
lana@huppenkothen.com

### SLOVENIA (SVN)

/

#### Huppenkothen d.o.o.

Slovenčeva ulica 97, 1113 Ljubljana  
T +386 15 300 333 / F +386 15 300 344  
ljubljana@huppenkothen.com

The complete  
Huppenkothen  
product range

